

**!WARNING!**

SPACE BETWEEN DOOR AND HOISTWAY  
MUST NOT EXCEED 3"

INTERLOCKS CONFORMING TO ASME A17.1  
MUST BE INSTALLED AND ADJUSTED PER  
THE MANUFACTURER'S INSTRUCTIONS.

**!FAILURE TO COMPLY  
MAY RESULT IN SERIOUS  
INJURY OR DEATH!**

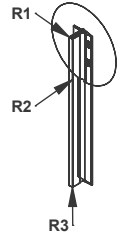
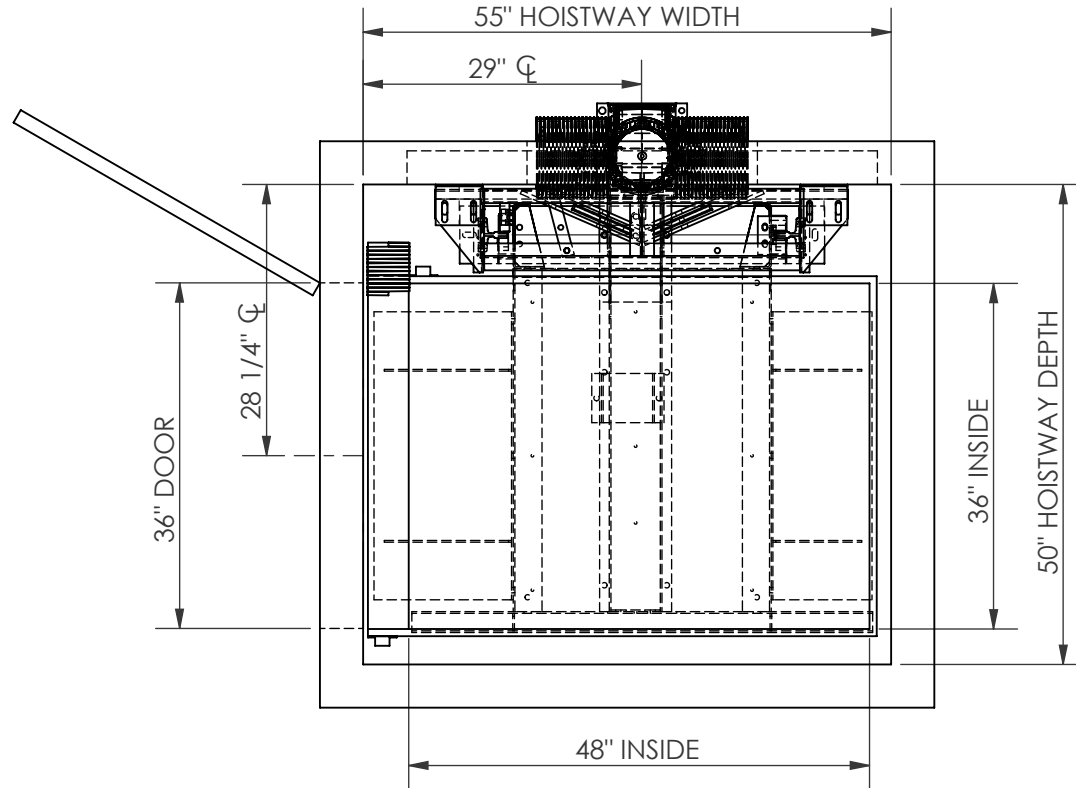
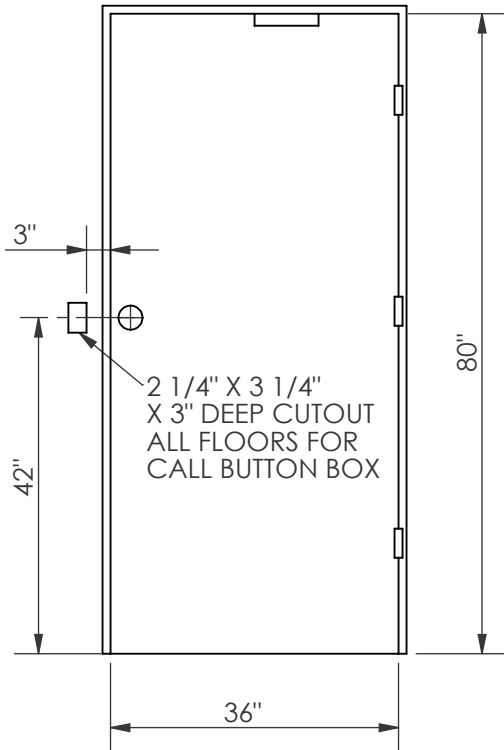
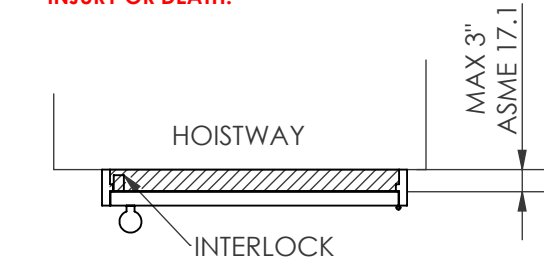

RAIL WEIGHT: 8 lbs/ft

RAIL FORCES

\*R1(Fx) 1075 lbs

\*R2(Fy) 358 lbs

R3(Fz) 2500 lbs

SIZE **A**  **Nationwide Lifts**  
America's *leader* in home elevators.

PART NO.  
**36 X 48, 1L**  
SHEET 1 OF 3  
DESCRIPTION:  
SWING DOORS, BASEMENT DRUM

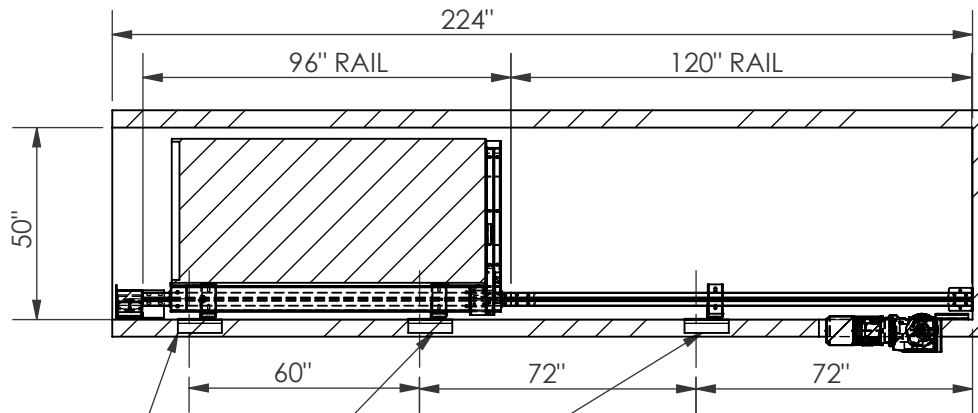

BRACKET LOCATIONS MAY VARY ACCORDING TO TRAVEL

PROVIDE WALL CONSTRUCTION SUITABLE FOR ATTACHMENT OF RAIL BRACKETS AT SHOWN ELEVATION. MUST BE CAPABLE OF 300LB PULLOUT LOADING WITH MAX DEFLECTION OF 1/8".

SPREADER BRACKETS FASTEN WITH LAG SCREWS 2 PLACES PER SIDE BRACKET

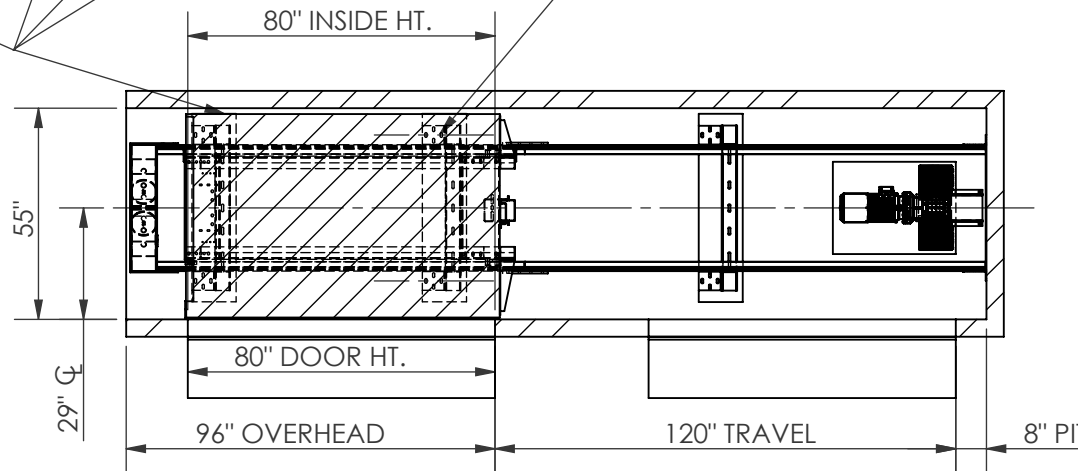

SIZE <b>A</b>	 America's <i>leader</i> in home elevators.
PART NO. <b>36 X 48, 1L</b>	
SHEET 2 OF 3	
DESCRIPTION: SWING DOORS, BASEMENT DRUM	

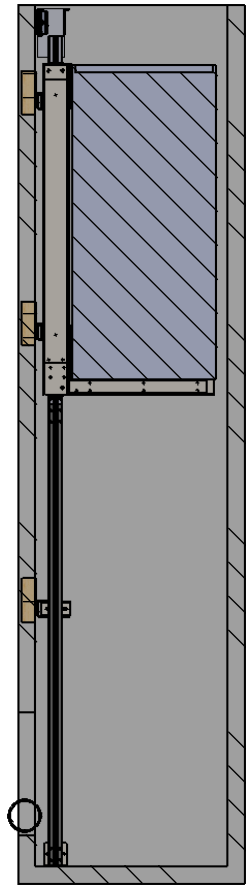
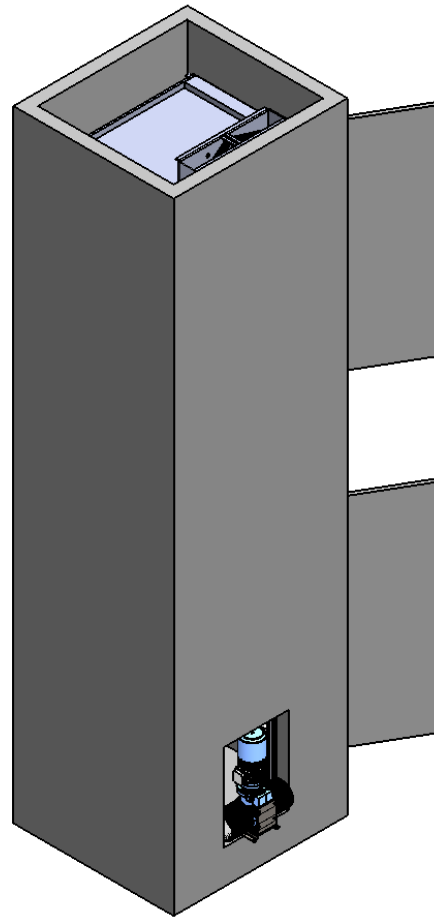
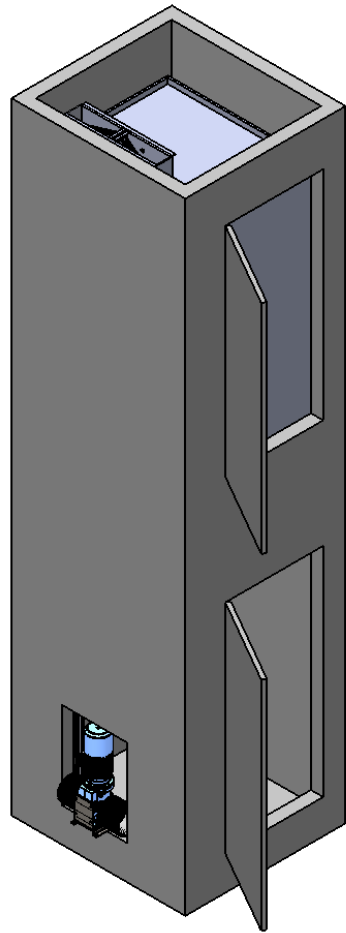

5



4

3

2

1

SIZE <b>A</b>	 <b>Nationwide Lifts</b> <i>America's leader in home elevators.</i>
PART NO. <b>36 X 48, 1L</b>	
SHEET 3 OF 3	
DESCRIPTION: SWING DOORS, BASEMENT DRUM	